

J.B. CONCRETE PRODUCTS, INC.

DB 3 - MA 4 HOLE DISTRIBUTION BOX

DATE:
Jan. 3, 2008

Drawing I.D.
DB3_MA

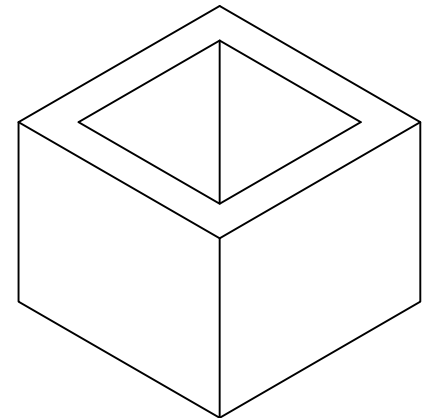
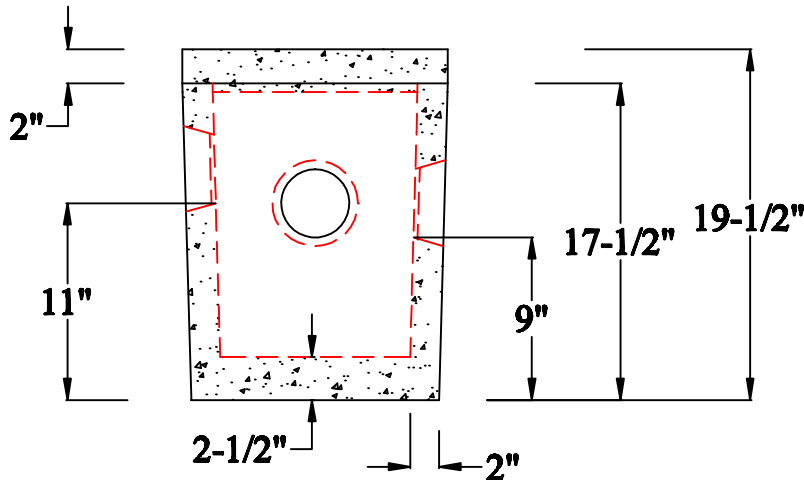
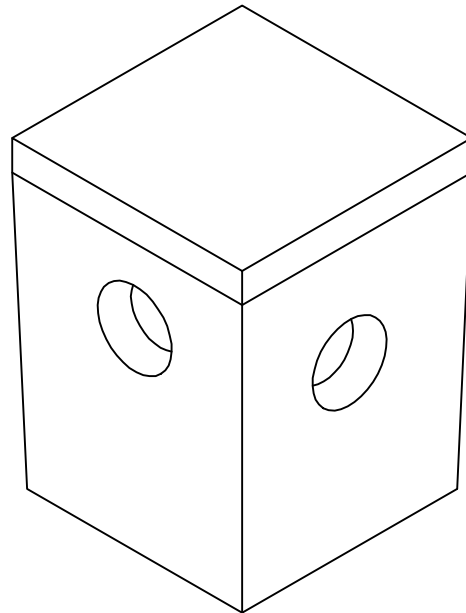
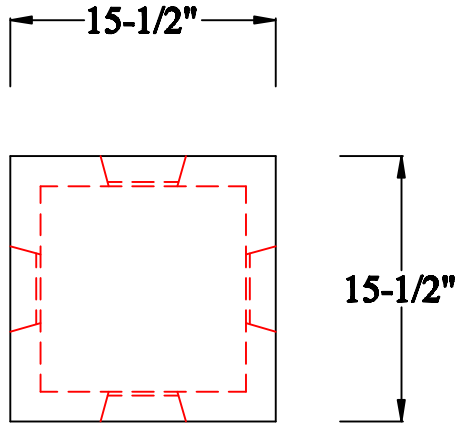

12" Riser Optional

Notes:

1. MINIMUM CONCRETE COMPRESSION STRENGTH 5,000 PSI AFTER 28 DAYS.
2. ONE (1) 4" INLET, THREE (3) 4" OUTLETS.
3. STATE APPROVED INLET AND OUTLET PIPE SEALS.
4. 12" RISERS AVAILABLE.

1 Arch St
PO Box 387
Putnam, CT 06260
(860)928-9365
F (860)928-9452
www.jbconcreteproducts.com