

J.B. CONCRETE PRODUCTS, INC.

DIPPER BOX

DATE:
Jan. 3, 2008

Drawing I.D.
DIPPER BOX

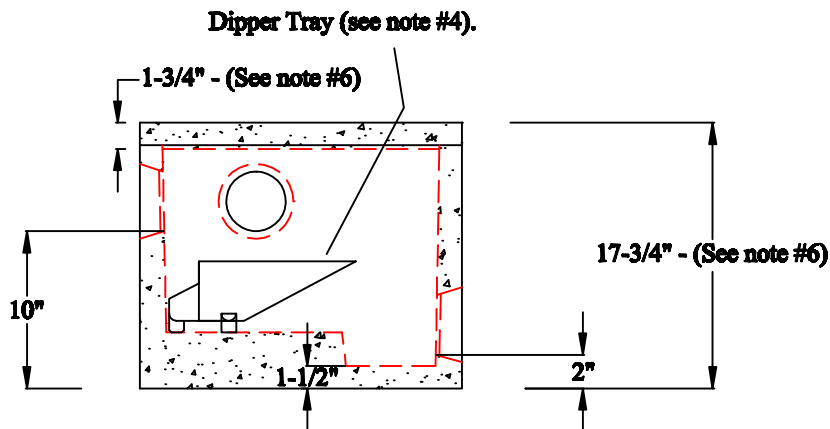
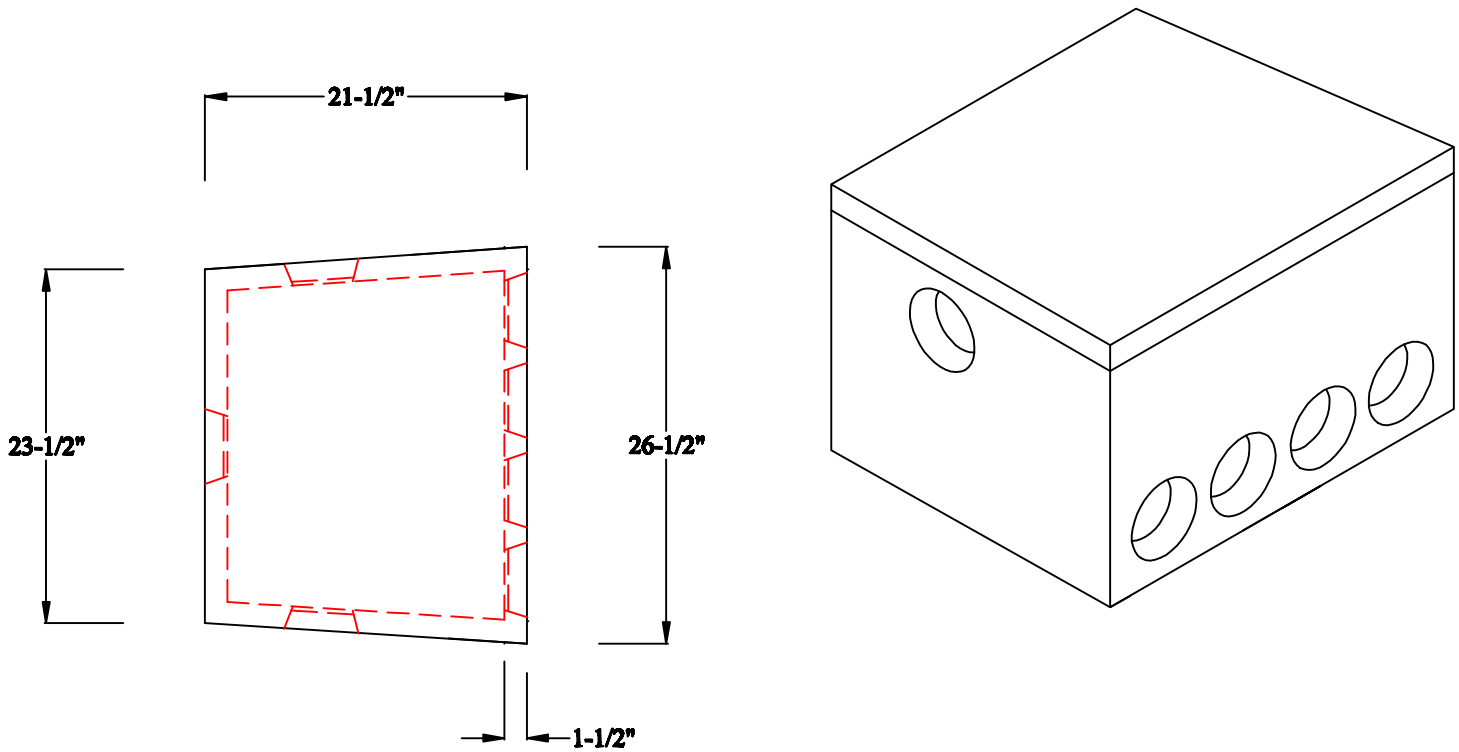

Notes:

1. MINIMUM CONCRETE COMPRESSION STRENGTH 5,000 PSI AFTER 28 DAYS.
2. THREE (3) 4" INLETS, FOUR (4) 4" OUTLETS.
3. DIPPER TRAY INCLUDED.
4. DIPPER TRAY ATTACHED TO CASTING AT TWO PIVOT POINTS ON EITHER SIDE OF PLASTIC TRAY TO ALLOW FOR UNIFORM DOSING.
5. STATE APPROVED INLET AND OUTLET PIPE SEALS.
6. OPTIONAL 3" THICK COVER W/ CAST IN 12" HDPE RISER AND COVER.

1 Arch St
PO Box 387
Putnam, CT 06260
(860)928-9365
F (860)928-9452
www.jbconcreteproducts.com