

J.B. CONCRETE PRODUCTS, INC.

4'X4'X4' PUMP CHAMBER

DATE:
Jan. 3, 2008

Drawing I.D.
PC_380

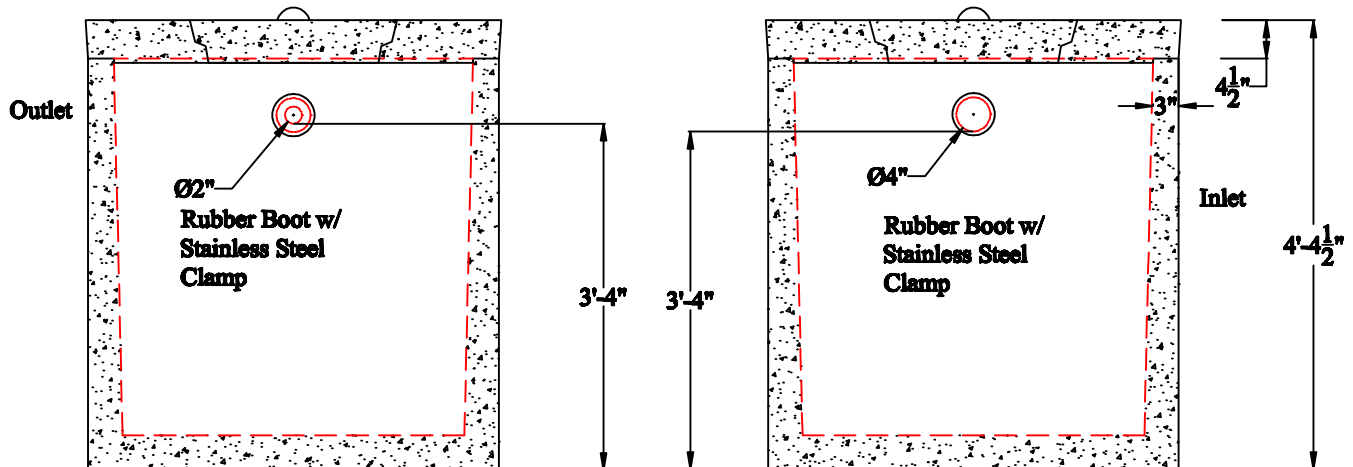
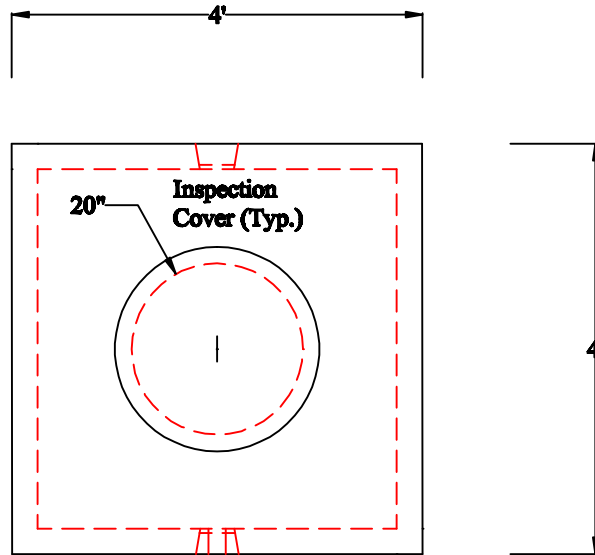

Notes:

1. CONFORMS TO ASTM C1227.
2. STATE APPROVED INLET AND OUTLET PIPE SEALS
3. MINIMUM CONCRETE COMPRESSION STRENGTH 5,000 PSI AFTER 28 DAYS.
4. APPROX. CAPACITY - 380 GAL.
5. JOINTS SEALED WITH BUTYL RUBBER SEALANT

1 Arch St
PO Box 387
Putnam, CT 06260
(860)928-9365
F (860)928-9452
www.jbconcreteproducts.com