

J.B. CONCRETE PRODUCTS, INC.

RAIN DRAIN

DATE:
March. 4, 2008
Drawing I.D.
RAIN_DRAIN

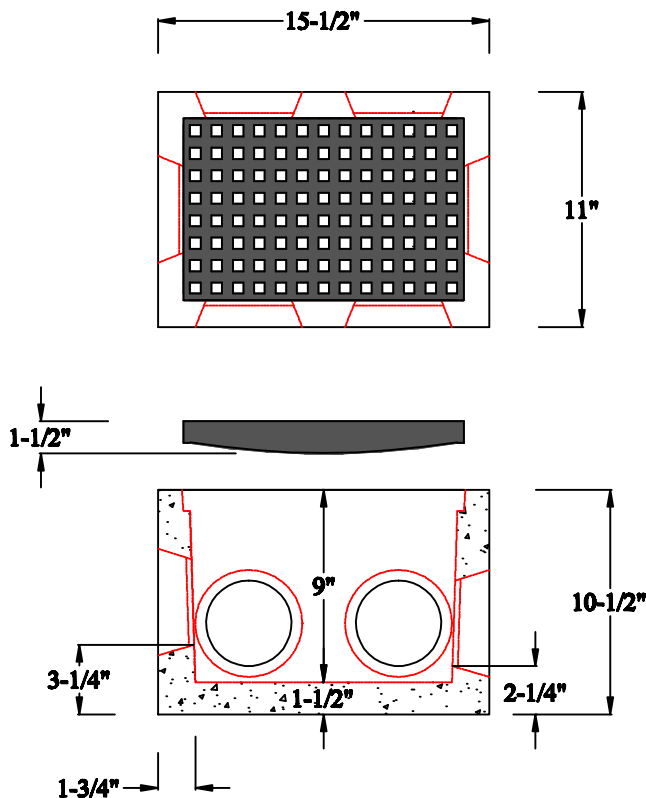
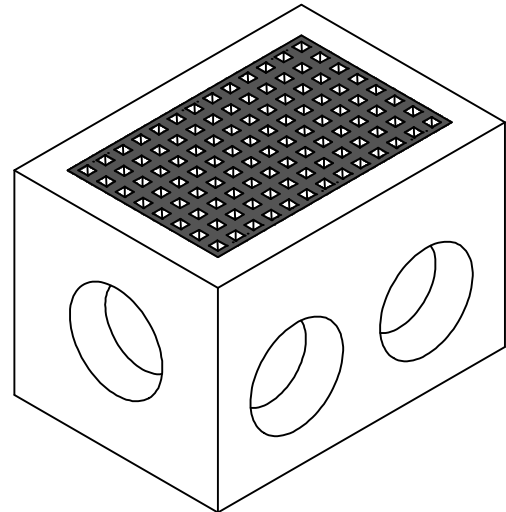

Notes:

1. RAIN DRAINS AVAILABLE WITH BLACK CO-POLYMER POLYPROPYLENE GRATES.
3. MINIMUM CONCRETE COMPRESSION STRENGTH 5,000 PSI AFTER 28 DAYS.
4. ONE (1) 4" INLET, FIVE (5) 4" OUTLETS
5. INLETS AND OUTLETS ACCEPT 2", 3", 4" SCH 40, SDR 35 AND CORRUGATED PIPE WITH NO GROUTING NECESSARY.

1 Arch St
PO Box 387
Putnam, CT 06260
(860)928-9365
F (860)928-9452
www.jbconcreteproducts.com