

J.B. CONCRETE PRODUCTS, INC.

24" DIA. H20 RISERS

DATE:
July 11, 2014

Drawing I.D.
TANKRISER_24H20

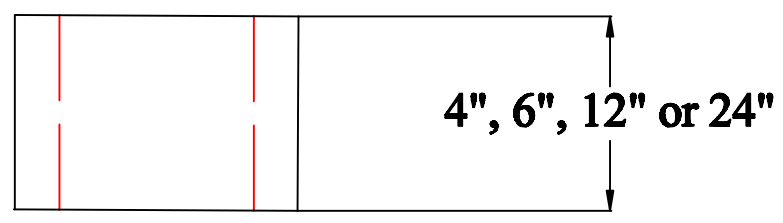
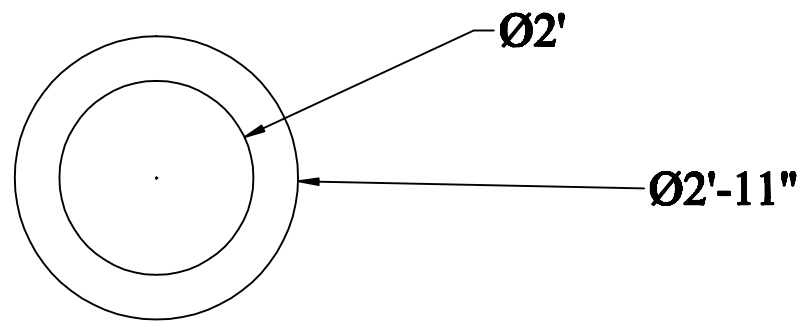

Notes:

- 1. MINIMUM CONCRETE COMPRESSION STRENGTH 5,000 PSI AFTER 28 DAYS.
- 2. RECESSED LIFT HOOKS IN TOP OF CASTING FOR LIFTING

1 Arch St
PO Box 387
Putnam, CT 06260
(860)928-9365
F (860)928-9452
www.jbconcreteproducts.com