

# J.B. CONCRETE PRODUCTS, INC.

25" DIA. TANK RISERS

DATE:  
Jan. 3, 2008

Drawing I.D.  
TANKRISER\_30

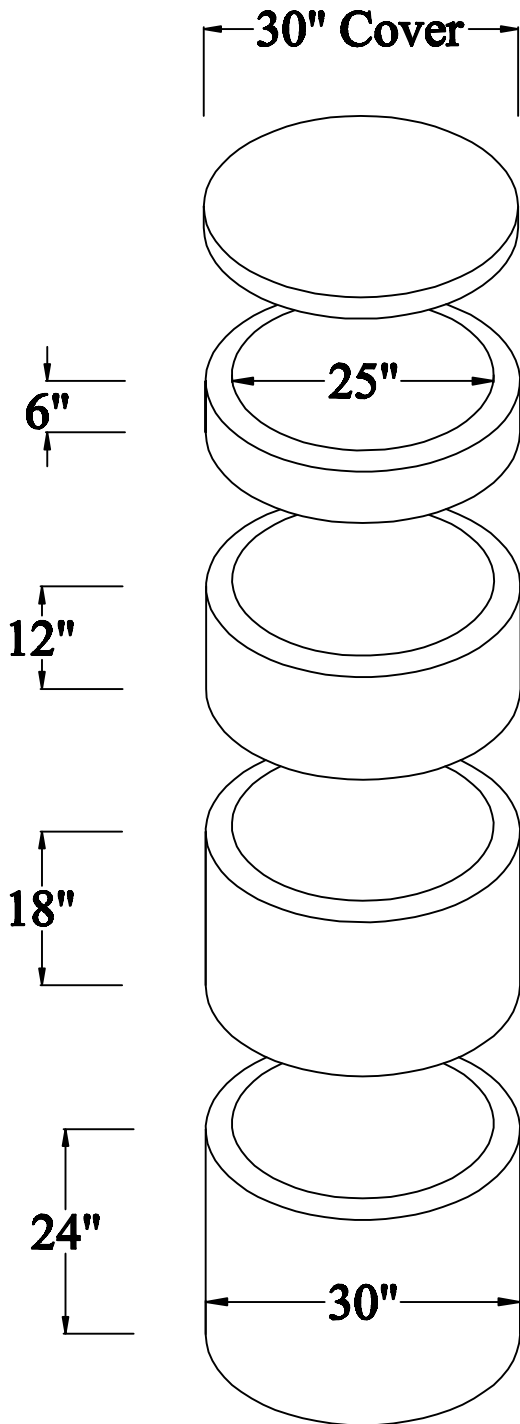

## COVER DETAIL

Flat Cover

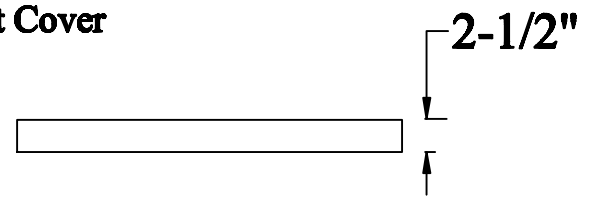

Locking Cover

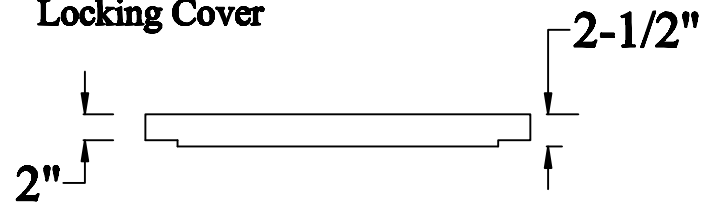

### Notes:

1. MINIMUM CONCRETE COMPRESSION STRENGTH 5,000 PSI AFTER 28 DAYS.
2. REINFORCED WITH WIRE MESH
3. RISERS USED TO EXTEND ACCESS FROM TANK TO GRADE LEVEL.
4. FLAT COVER STANDARD, LOCKING COVER OPTIONAL

1 Arch St  
PO Box 387  
Putnam, CT 06260  
(860)928-9365  
F (860)928-9452  
[www.jbconcreteproducts.com](http://www.jbconcreteproducts.com)