

# J.B. CONCRETE PRODUCTS, INC.

18" DIA. WELL TILE

DATE:  
Jan. 3, 2008

Drawing I.D.  
WELLTILE\_18

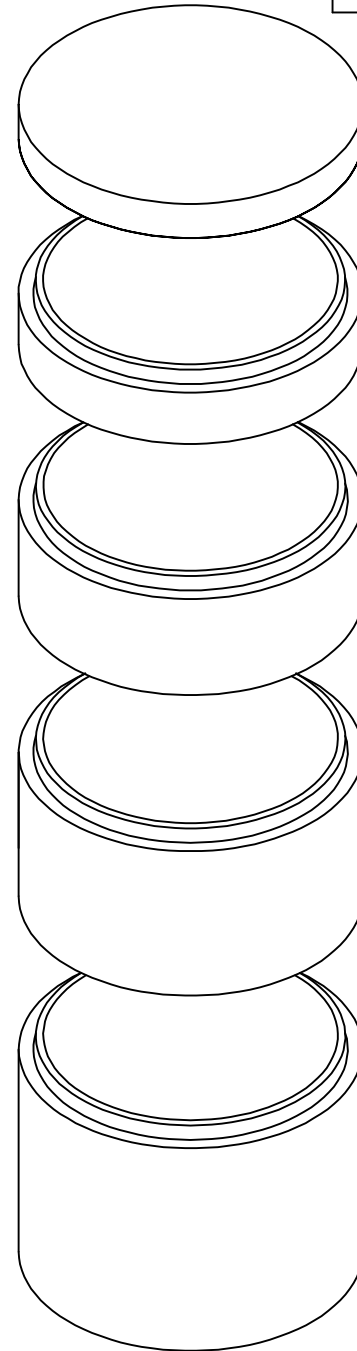
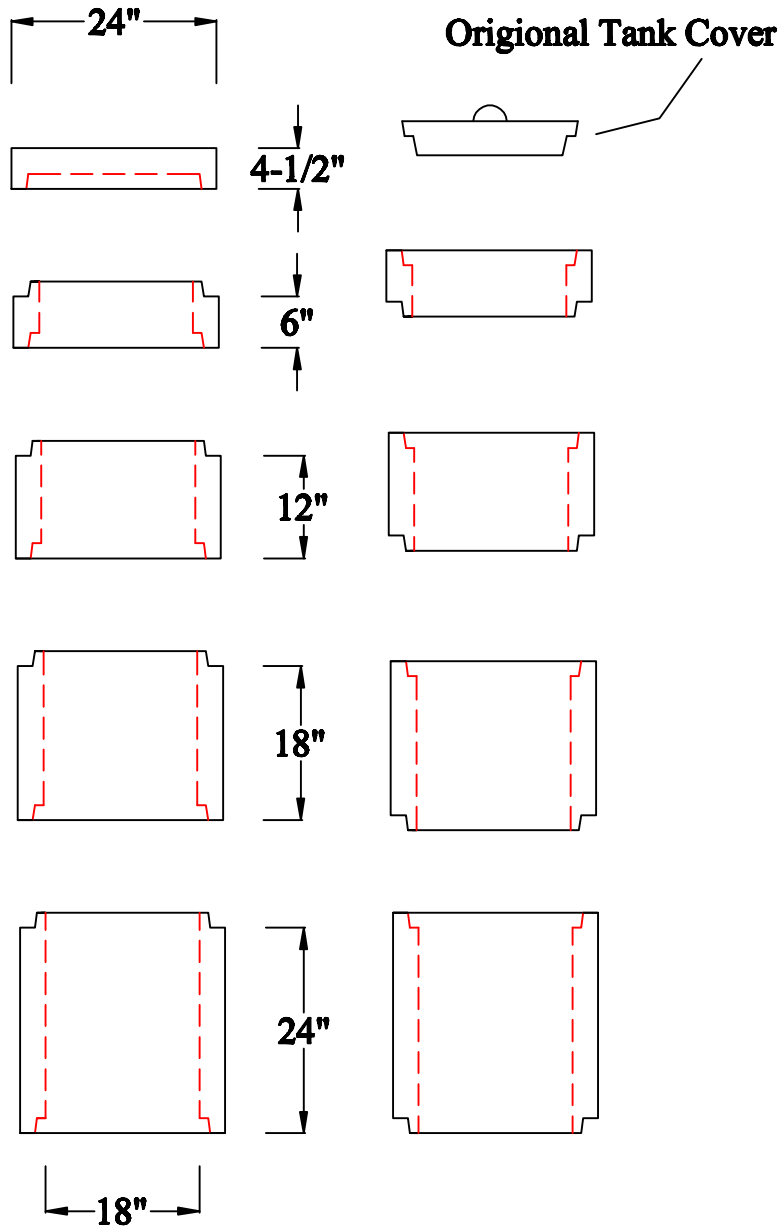

## Notes:

1. MINIMUM CONCRETE COMPRESSION STRENGTH 5,000 PSI AFTER 28 DAYS.
2. RISERS MAY BE USED IN EITHER MANNER SHOWN TO EXTEND ACCESS FROM TANK TO GRADE LEVEL.

1 Arch St  
PO Box 387  
Putnam, CT 06260  
(860)928-9365  
F (860)928-9452  
[www.jbconcreteproducts.com](http://www.jbconcreteproducts.com)